



Application Note

Improving Secondary Pumping
in Primary/Secondary Systems



VLT® 6000 HVAC

■ **The Application**

Secondary pumps in a primary/secondary chilled water pumping system are used to distribute the chilled water to the loads from the primary production loop. The primary/secondary pumping system is used to hydraulically decouple one piping loop from another. In this case, the primary pump is used to maintain a constant flow through the chillers while allowing the secondary pumps to vary in flow, increase control and save energy.

If the primary/secondary design concept is not used and a variable volume system is designed, when the flow rate drops far enough or too quickly, the chiller cannot shed its load properly. The chiller's low evaporator temperature safety then trips the chiller requiring a manual reset. This situation is common in large installations especially when two or more chillers in parallel are installed.

■ **The Design**

Figure 1 shows the traditional primary/secondary design. The primary pumps are sized to take care of the flow requirements and pressure drop in the production loop only. The larger secondary pumps are sized to circulate the water throughout the system. Decoupled from the primary, the secondary pumps no longer have minimum flow constraints and can utilize two-way valves and other energy saving methods without any complications to the chillers.

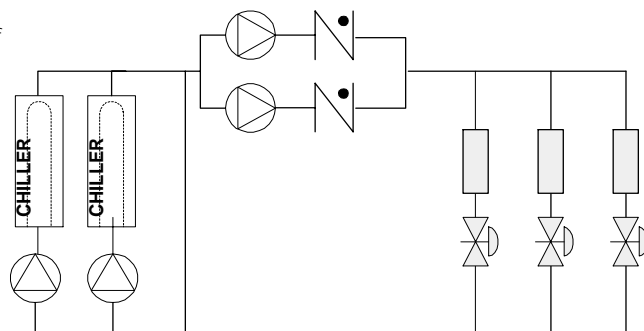

Fig. 1
Traditional primary/secondary system

The system curve defines the discharge pressure that the pumping system requires as the flow rate changes. As the flow rate increases, additional pressure is required to compensate for the increased resistance the piping and loads add. Likewise, as the flow rate decreases, the resistance in the system decreases. With the traditional system design and two-way valves, the discharge pressure must follow the pump curve, not the system curve. This means that the pump increases its discharge pressure as the flow decreases even though the system requires a lower discharge pressure.

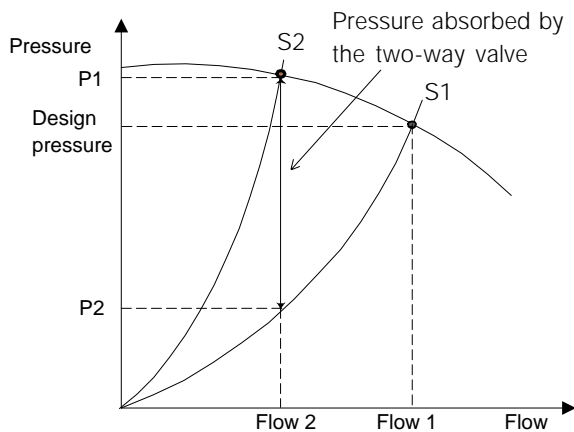

Fig. 2
Pressure absorbed by the two way valves

S1, S2 = System curves

The difference between the system curve and the pump curve is the pressure that the two-way valve must absorb. Figure 2 shows the pressure that must be absorbed by the two-way valve as the flow varies. As the systems flow requirements decrease from flow 1 to flow 2, the required pumping pressure is P2, but the constant speed pump produces P1. The difference must be absorbed by the two-way valves.

This pressure can hereby become greater than the valve is designed to hold resulting in the valve being forced open. This results in overcooling the nearby load zones while possibly undercooling a distant load. This situation can damage valves, create system leaks, and generally increase maintenance costs as well as waste energy.

■ The new standard

While the primary-secondary system with two-way valves improves energy savings and eases system control problems, the true energy savings and control potential is realized by adding VLT frequency converters. Figure 3 shows the system with VLT frequency converters properly implemented.

With the proper sensor location, the addition of VLT frequency converters allows the pumps to vary their speed to follow the system curve instead of the pump curve. The VLT frequency converter system operation is shown in Figure 4.

This results in the elimination of wasted energy and eliminates most of the over-pressurization the two-way valves can be subjected to.

As the monitored loads are satisfied, the loads two-way valves close down. This increases the differential pressure measured across the load and two-way valve. As this differential pressure starts to rise, the pump is slowed to maintain the control head also called setpoint value. This setpoint value is calculated by summing the pressure drop of the load and two way valve together under design conditions.



NB!

Please note that when running multiple pumps in parallel, they must run at the same speed to maximize energy savings, either with individual dedicated drives or one drive running multiple pumps in parallel.

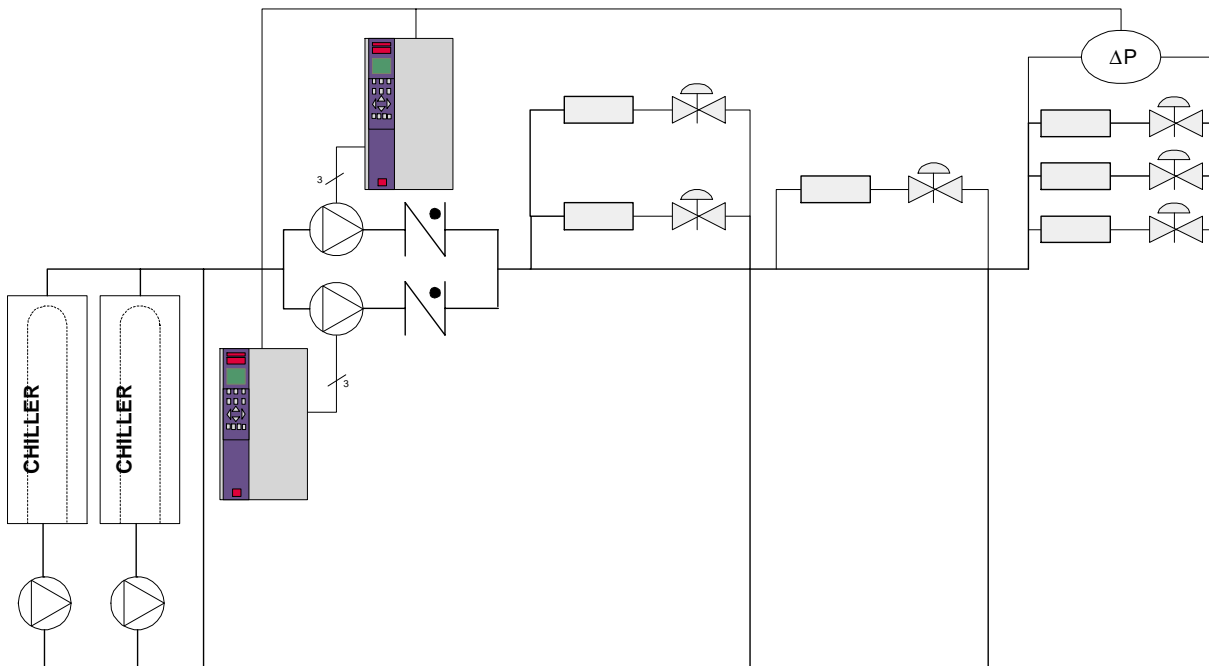

Fig. 3 - Primary/Secondary system with VLT frequency converters

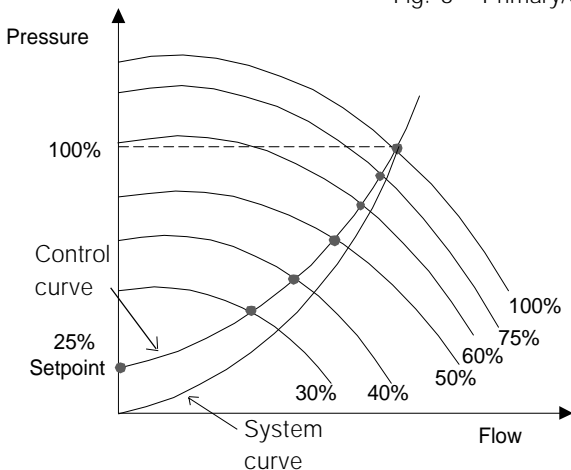

Figure 4: Variable Speed Pump Curves

The control curve, fig. 4, determines the actual operation points when operating on variable speed. The control head or setpoint is the amount of pressure that must be maintained even at zero flow to satisfy system requirements. The control curve represents the required increase in discharge pressure to compensate for the friction losses in the pipe network as flow increases. The lower the setpoint can be the greater the potential savings. (see also page 4 for correct sensor placement)

■ **Annual operation load profile**

To calculate your potential savings, one must look at the actual load profile.

The load profile indicates the amount of flow the system requires to satisfy its loads during the typical day or time period under study. Figure 5 shows a typical load profile for secondary chilled water pumps. This profile will vary depending on the specific needs of each system due to location, safety margins used in the design phase and other factors, but is representative of normal systems.

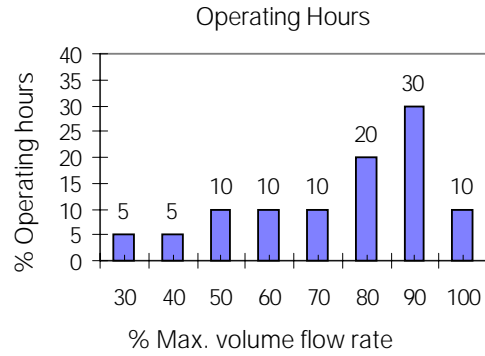

Fig. 5 Load Profile

■ **Energy saving calculation example**

In the following calculation example a 30 kW pump is operated according to the load profile shown in fig. 5. The energy consumption during one year of operation is calculated comparing a constant speed/variable volume system to a variable speed/variable volume system with a sensor setpoint of 25%. The comparison shows energy savings of over 32%.

Flow (%)	Hours (%)	Hours run	Power Consumption (kW)		Energy input for 30 kW Pump motor	
			2-way valves	VLT 6000 HVAC	2-way valves	VLT 6000 HVAC
30	5	438	23,33	4,73	10219	2073
40	5	438	23,56	6,08	10321	2663
50	10	876	24,03	8,01	21047	7014
60	10	876	24,71	10,61	21647	9298
70	10	876	25,62	14,04	22441	12300
80	20	1752	26,76	18,54	46886	32483
90	30	2628	28,17	24,28	74027	63814
100	10	876	30,22	31,48	26470	27573
100%		8760 Hours			233058 kWh	157218 kWh

Fig. 6: Energy consumption comparison

■ **Sensor Type And Placement**

The energy savings capabilities of a properly installed VLT frequency converter system is well known. However, the importance the sensor type and placement has on these calculations is often overlooked. To achieve the expected energy savings, it is critical that the sensors are placed properly in the system.

For Secondary Pumping systems, a differential pressure sensor should be used. It is important to place the sensors at the furthest possible major load or loads. This allows the VLT frequency converter system to take advantage of the decreased resistance in the piping network, known as the variable head losses, as the flow decreases.

The control head requirement is now reduced to the static demands of the system. The sensors should detect the differential pressure across the load and its accompanying two-way valve as shown in Fig 7.

Many installers have unwittingly installed the differential pressure sensor directly across the pump to reduce installation costs. Figure 7 shows the impact the sensor placement has on energy savings.

Using the same load profile (fig. 5) the impact the setpoint has on savings can be seen.

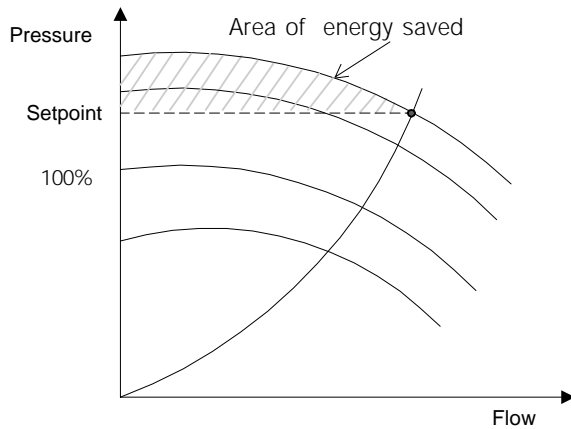
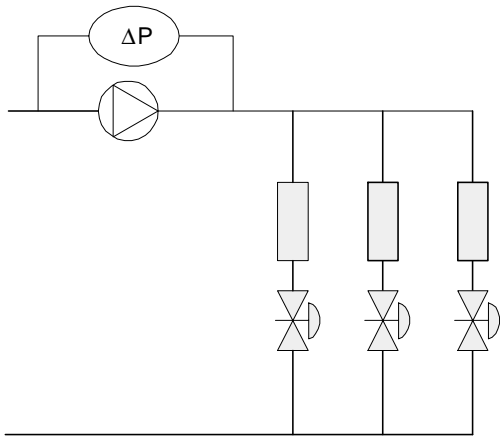

Energy consumption with 100% setpoint
 Total energy consumption per year: 220942 kWh
 Annual savings: (12116 x US\$ 0.10) US\$ 1212

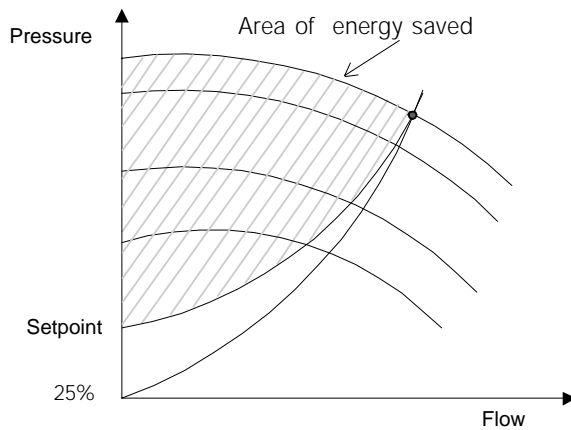
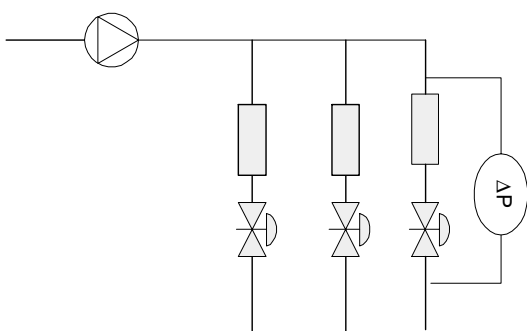

Energy consumption with 25% setpoint
 Total energy consumption per year: 157218 kWh
 Annual savings: (75840 x US\$ 0.10) US\$ 7584

Figure 7



Danfoss can accept no responsibility for possible errors in catalogues, brochures and other printed material. Danfoss reserves the right to alter its products without notice. This also applies to products already on order provided that such alterations can be made without subsequential changes being necessary in specifications already agreed.
All trademarks in this material are property of the respective companies. Danfoss and the Danfoss logotype are trademarks of Danfoss A/S. All rights reserved.



Wallace Eannace Associates, Inc.

**50 New Town Road
Plainview, NY 11803
Tel: 516-454-9300
Fax: 516-454-9307**

**779 Susquehanna Avenue
Franklin Lakes, NJ 07417
Tel: 201-891-9550
Fax: 201-891-4298**

175R0104

MN60E102



Rev. 2003-09-11

© Copyright Danfoss, Inc., 2004